

Innovative Power Engineering at its best!

HUGHES
POWER SYSTEM

LOAD BREAK SWITCH

FOR OVERHEAD LINES

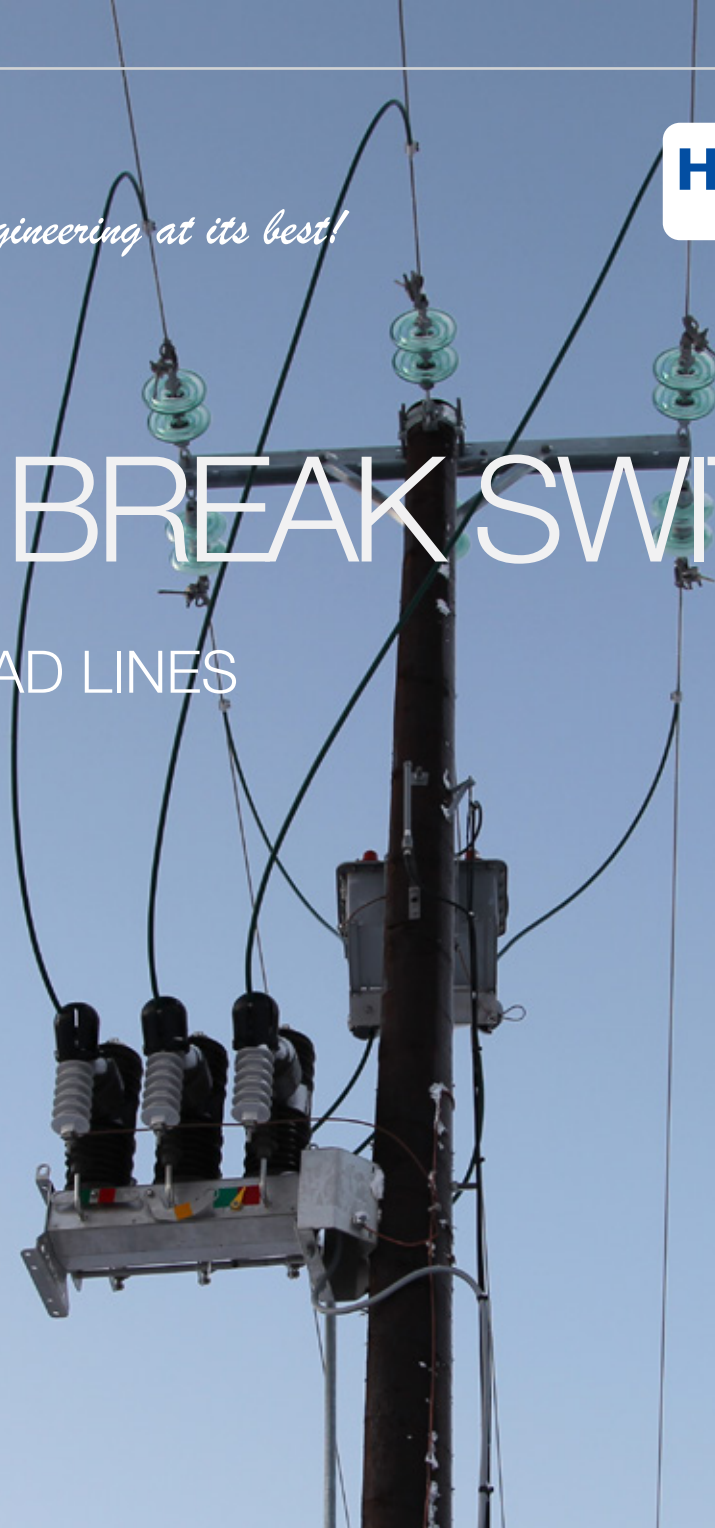

LBS OVERHEAD LINES LOAD BREAK SWITCH
SERIES FOR DIFFERENT VOLTAGE CLASSES:

- LBS120 series for 6/15kV;
- LBS240 series for 22/27kV;
- LBS405 series for 33/40kV;

ABOUT US

Hughes Power System is a Swedish manufacturer of environmentally friendly equipment for electrification and automation of mass transport and electrical distribution systems. Very high quality standards together with innovative approach result in an advanced range of products, aiming to improve network quality by minimizing the number and duration of faults.

Our product portfolio includes:

- Reclosers
- Vacuum interrupter switches
- Disconnectors
- Motor drives
- Voltage transformers
- D/C power supplies

With its more than 30 years expertise in research, development, manufacturing, marketing and sales the company operates in many countries though cooperation with local partners. As we move towards our goal of being a world class advanced technological company in electrical utility products, we guarantee our commitment to the well known Swedish standards of reliability, safety and quality.

The majority of Hughes Power System's products are designed and built in Sweden.



LBS LOAD BREAK SWITCHES

GENERAL DESCRIPTION



WHAT IS A LOAD BREAK SWITCH

Hughes LBS overhead line load break switch is a control system, including a vacuum circuit breaker and an optional control cabinet for remote control.

LBS series built for overhead distribution lines for sectionalizer applications or as a very reliable and safe alternative to a disconnecter / air break switch.

The products are built to remain in operation for more than 30 years without major maintenance due to the highest quality materials used in its construction.

LBS LOAD BREAK SWITCH SET INCLUDES:

- The **CXB-1** (1) control unit for remote control of a switch (optional);
- **LBS** (2) vacuum load break switch (compulsory);
- Interconnecting cable (3) (optional);
- Built in components (optional);
- External accessories (4) (optional);

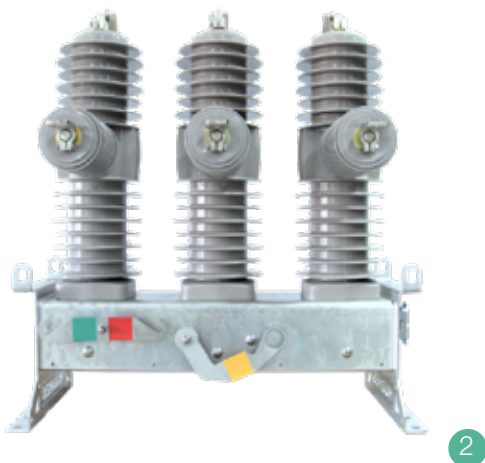

OPERATION PRINCIPLE

- The LBS series of load break switches can be operated manually or motorized for remote control;
- The manual operation is performed by a hook stick or by a fixed operation rod. If a down pole operation handle (1) is used, it can be pad locked in open or closed position;
- There are two different motor/spring mechanisms, A and B versions that have different operation principles;
- The A version is a solenoid release mechanism that has the operation springs charged all the time. It is released by an electric solenoid (ca 25 ms delay) or by a manual operation mechanism. This mechanism has stored spring energy for 3 operations before it needs to be charged;
- The B version is a traditional spring mechanism that charges the spring in the same operation as it is operated. It is normally operated by a hook stick or via a fixed down pole operation rod and a operation handle (1). It can there be pad locked in open or closed position;

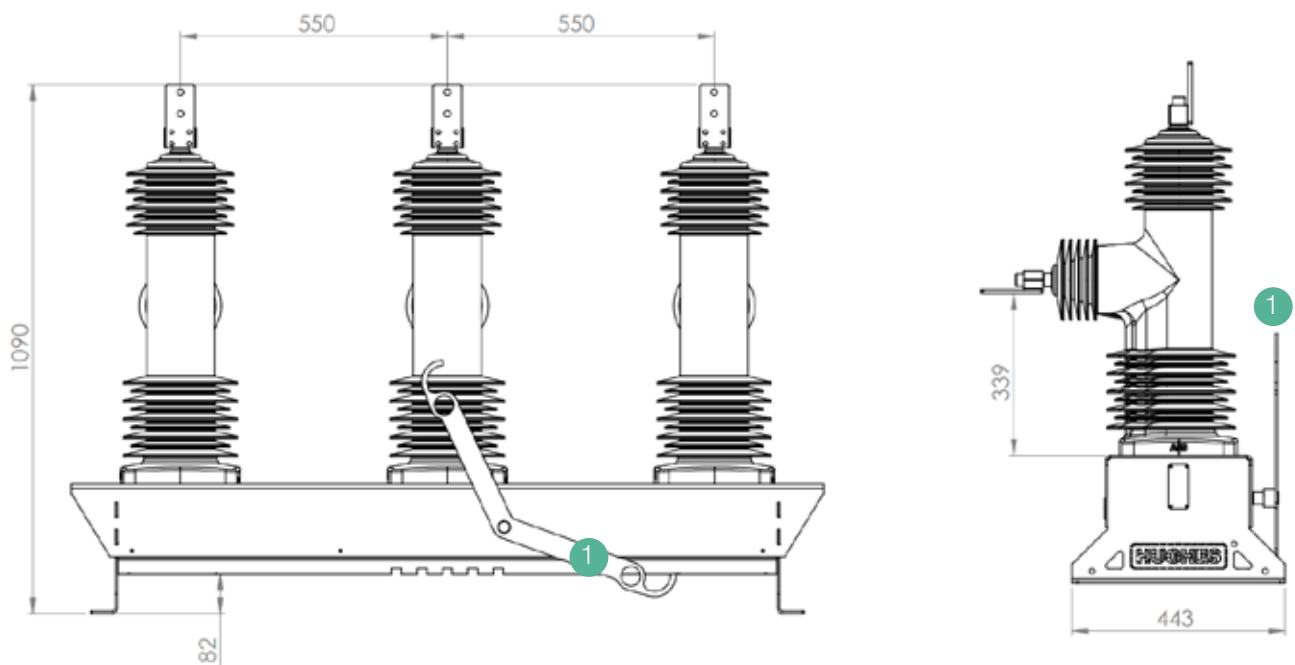

LBS SERIES FOR LOAD BREAK SWITCHES MODEL RANGE

- **LBS120** has the LBS120 vacuum load break switch equipped with 12kV bushings and a built-in disconnector;
- **LBS121** has the LBS121 vacuum load break switch equipped with extra insulated 27kV bushings and an optional set of voltage sensors on feed side;
- **LBS240** has the LBS240 vacuum load break switch equipped with 24kV bushings and a built-in disconnector;
- **LBS241** has the LBS241 vacuum load break switch equipped with extra insulated 27kV bushings and an optional set of voltage sensors on feed side;
- **LBS405** has the LBS405 vacuum load break switch equipped with ABB VG10 2000A/20kA 40.5kV vacuum interrupter and voltage sensors on the load side;

LBS LOAD BREAK SWITCHES

GENERAL DESCRIPTION

LBS VACUUM LOAD BREAK SWITCH COMPONENTS AND ADVANTAGES

Hughes **LBS** series of load break switches has the following advantages:

- **Low maintenance.** Hughes load break switches are built to remain in operation for more than 30 years without major maintenance due to the highest quality materials used in its construction;
- **Low initial investment cost.** LBS can operate with or without fault pass indicator and radio. The local operation is performed with a hook stick, fixed operation rod or via push buttons in a control cabinet. The remote control is performed via the control cabinet with the communication options: SMS, MODBUS, DNP3 and IEC 60870-5-101/104 serial and IP communication via radio-GSM.
- **Long operational life time.** Up to 20,000 interruptions (one of the longest operating life on today's market) of the well proven LBS load break switch;
- **Optimized operation.** In order to save service life of ordinary air break switches and ensure the immediate restoration of the power supply, the LBS can handle all type of switching operations in the network. Almost all damaged air break switches are due to few over loaded switching situation. Overloaded switching operations can easily create bush and forest fire due to burning metals from open air break switch contacts;
- **Unlimited number** of LBS's can be installed with an downstream recloser in the trunk line or branches of the overhead line to sectionalize the network in small sections.
- Operates in combinations of **reclosers and sectionalizers**;
- LBS can **make and break short circuit currents** if needed, both electronically and mechanically.
- **Simple setup** with a LBS vacuum load break switch and an optional CBX-1 control unit;
- **Simple upgrade** of LBS to a recloser is possible via replacement of the control cabinet software;

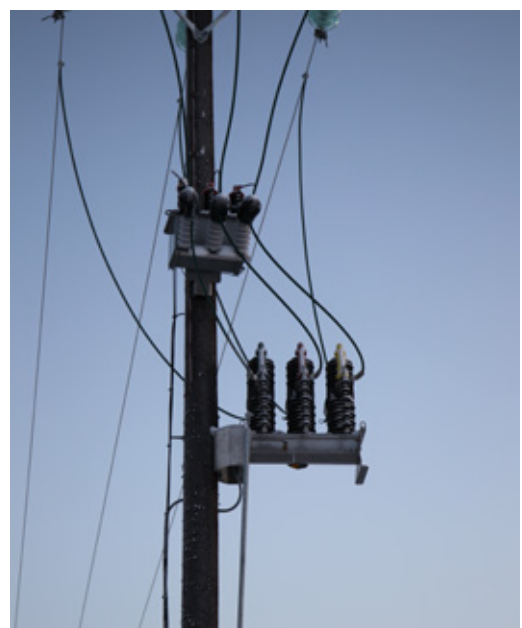

Hughes **LBS** series of vacuum load break switches is a modular building system, enabling to build easy tailored switches for different qualified solutions. It has the following components and advantages:

- **Bushings and insulators** (1) with solid epoxy insulation. Silicon coating provides UV protection, is environmentally friendly, does not contain harmful SF6 gas or oil;
- **Frame** (2) made of 5 and 4mm highest quality stainless steel to minimize electrochemical corrosion. The use of stainless steel in accordance with DIN50049 / 3.1B, thanks to its non-magnetic properties, completely eliminates the occurrence of any kind of corrosion, including electrochemical corrosion over the entire life of the product;
- **Electrical circuit** (3) made of high grade copper;
- **Attachment points** (4) for down pole mounted disconnector operation handle;
- **Spring stored energy operating mechanism** (5). It provides turning On and Off the switch module even in the complete absence of power supply (voltage transformer malfunction, full battery discharge).
- **Manual maneuvering** (6) of LBS. Manual charging of the spring mechanism as well as switch operation On and Off are possible with the help of manoeuvring arms located on a switch body. The spring capacity is enough for the full reclosing cycle (Off - On - Off) without recharging;
- **Disconnecter switch** (7) gives visible open points of all three phases for extra safety. The disconnecter (for LBS120 and 240 only) is synchronized with the vacuum interrupter and cannot be open or closed when the vacuum interrupter is closed;

OPTIONAL COMPONENTS:

- **1 set of voltage sensors** (8) can be installed on feed side (for LBS121 and 241) or on load side (for LBS405);

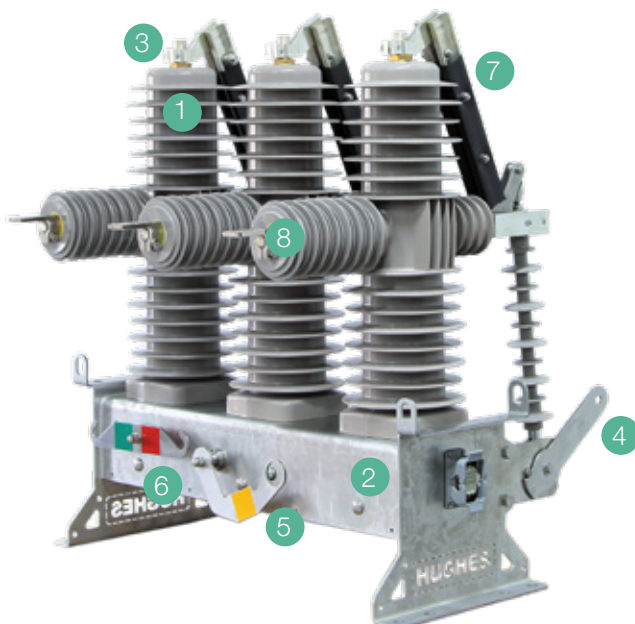

LBS LOAD BREAK SWITCHES

GENERAL DESCRIPTION

CXB-1 CONTROL CABINET ADVANTAGES

Hughes LBS series uses **CXB-1** control cabinet for control of load break switches with the following advantages:

- **Complete solution** from a pole to SCADA system;
- **Easy installation** and compatible with most disconnectors;
- **Compact design**;
- **External cabinet** (1) of highest quality stainless steel. The use of stainless steel in accordance with DIN50049 / 3.1B, thanks to its non-magnetic properties, completely eliminates the occurrence of any kind of corrosion, including electrochemical corrosion over the entire life of the cabinet;
- **Special double roof** (2) prevents the accumulation of the water / snow on the cabinet and protects from overheating of the internal cabinet in hot climates;
- **Padlock facility** (3) handle protects from unauthorized access;
- **Protection lips** (4) from rain water;
- **Connector** (5) for antenna remote control;
- Rugged pole **mounting brackets** (6) for different pole types;
- **Door alarm switch** (7) activates when the door is opened and sends the signal to the SCADA system. This feature notifies about access to the cabinet;
- **Inventive climate system** (8) for long term reliability. The lower louvers have a combination of a polymeric fine filter and a PTC thermoelement, which creates a moving air stream to the upper louvers. This air stream always evens out the day and night effect. The bottom of the cabinet has 5 drainage holes with micro filter preventing water gathering in case of any condensation;
- **Inventive protection system** from water ingress via the outgoing drive shaft;
- **Communication** to the control centre can be done via SMS, MODBUS, DNP3 and IEC 60870-5-101/104 serial and IP communication via radio-GSM;



LBS120 SERIES FOR 6/15KV

LBS120 COMPONENTS

Hughes **LBS120** load break switch for 6/12kV has the following components:

- **12kV bushings** (1) of epoxy with silicone surface;
- Integrated and synchronized **disconnecter** (2) with visible open points on all 3-phases;
- **Attachment points** (3) for down pole mounted disconnecter operation handle;
- **Frame** (4) made of 5 and 4mm stainless steel to eliminate corrosion;
- **Electrical circuit** (5) made of high grade copper;
- **Manual maneuvering** (6) of vacuum interrupter;
- **Spring stored energy operating mechanism** (7);

OPTIONAL COMPONENTS:

- **1 set of voltage sensors** (6) on load side;

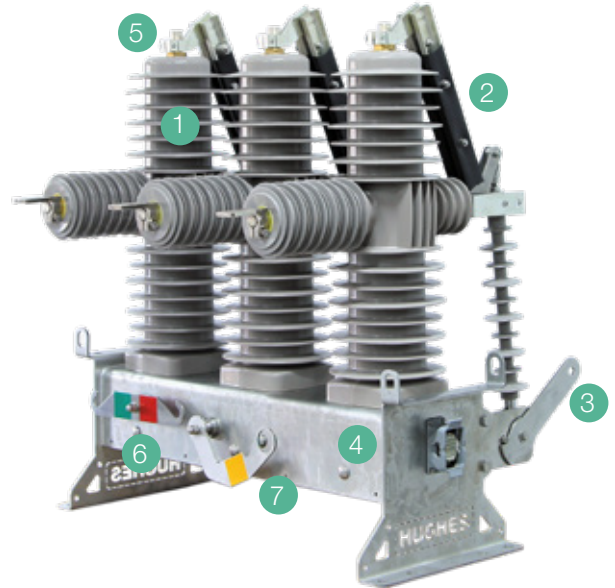

LBS121 COMPONENTS

Hughes **LBS121** load break switch for 6/15kV has the following components:

- **27kV bushings** (1) of epoxy with silicone surface;
- **Attachment points** for down pole mounted disconnecter operation handle;
- **Frame** (2) made of 5 and 4mm stainless steel to eliminate corrosion;
- **Electrical circuit** (3) made of high grade copper;
- **Manual maneuvering** (4) of vacuum interrupter;
- **Spring stored energy operating mechanism** (5);

OPTIONAL COMPONENTS:

- **1 set of voltage sensors** (6) on feed side;

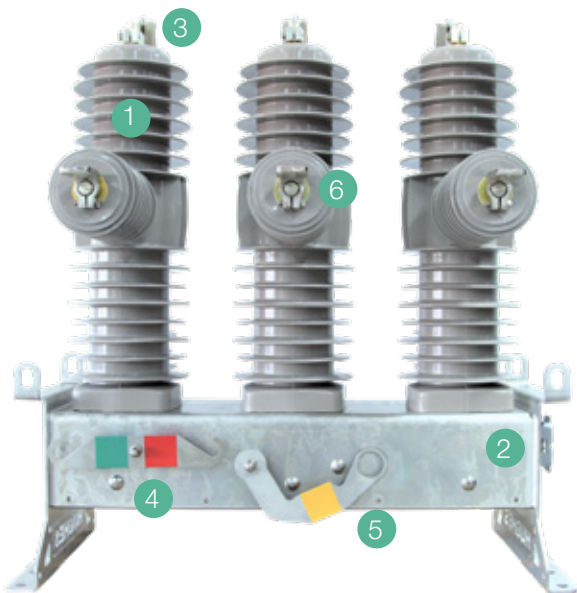

LBS LOAD BREAK SWITCHES

LBS240 SERIES FOR 22/27KV

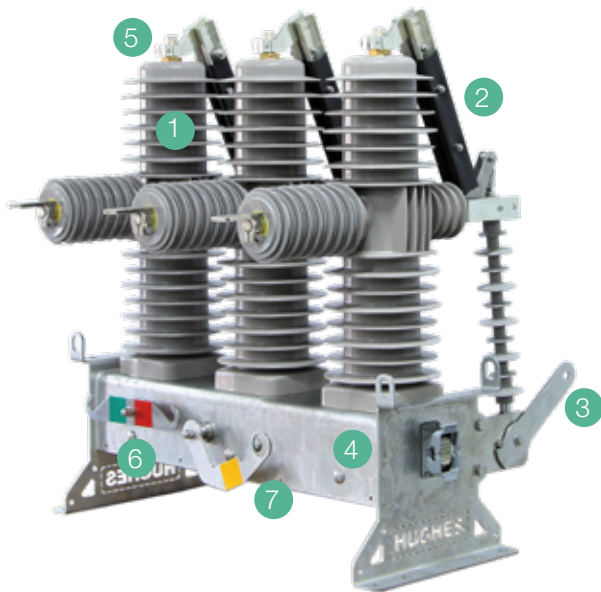

LBS240 COMPONENTS

Hughes **LBS240** load break switch for 22/27kV has the following components:

- **24kV bushings** (1) of epoxy with silicone surface;
- Integrated and synchronized **disconnect** (2) with visible open points on all 3-phases;
- **Attachment points** (3) for down pole mounted disconnect operation handle;
- **Frame** (4) made of 5 and 4mm stainless steel to eliminate corrosion;
- **Electrical circuit** (5) made of high grade copper;
- **Manual maneuvering** (6) of vacuum interrupter;
- **Spring stored energy operating mechanism** (7);

OPTIONAL COMPONENTS:

- **1 set of voltage sensors** (6) on load side;

LBS241 COMPONENTS

Hughes **LBS241** load break switch for 22/27kV has the following components:

- **27kV bushings** (1) of epoxy with silicone surface;
- **Attachment points** for down pole mounted disconnect operation handle;
- **Frame** (2) made of 5 and 4mm stainless steel to eliminate corrosion;
- **Electrical circuit** (3) made of high grade copper;
- **Manual maneuvering** (4) of vacuum interrupter;
- **Spring stored energy operating mechanism** (5);

OPTIONAL COMPONENTS:

- **1 set of voltage sensors** (6) can be installed on feed side;

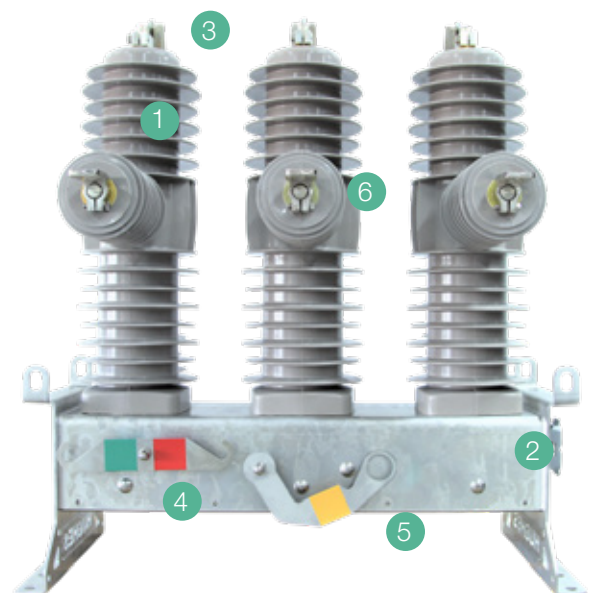

LBS405 FOR 33/40KV

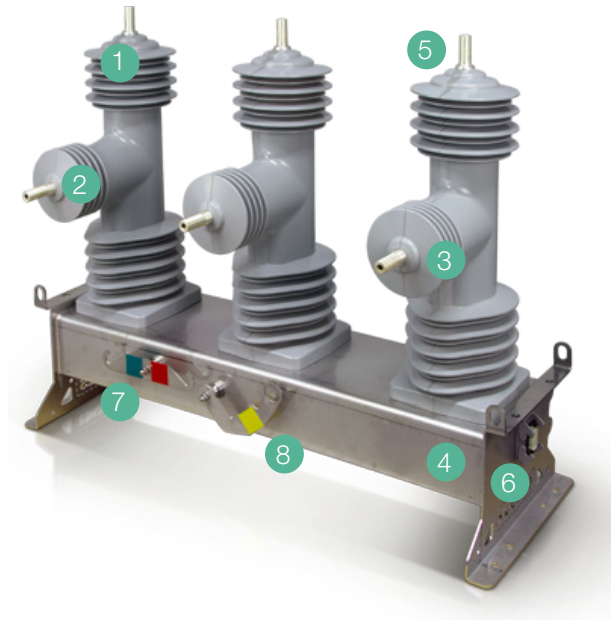

LBS405 COMPONENTS

Hughes **LBS405** load break switch for 33/40kV has the following components:

- **ABB VG10 2000A/20kA 40.5kV** vacuum interrupter (1);
- Integrated 3x **phase current transformers** (2);
- Integrated **voltage sensors** (3);
- **Frame** (4) made of 5 and 4mm stainless steel to eliminate corrosion;
- **Electrical circuit** (5) made of high grade copper;
- **IP67** Control cable contact (6);
- **Manual maneuvering** (7) of vacuum interrupter;
- **Spring stored energy operating mechanism** (8);

DRAWINGS

LBS405

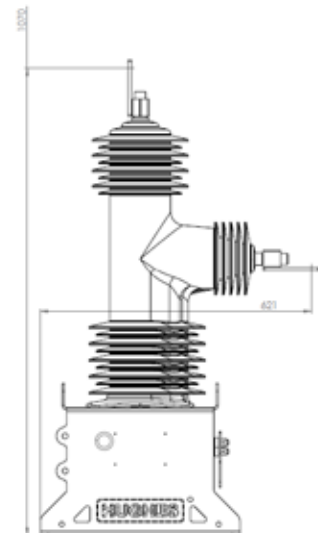
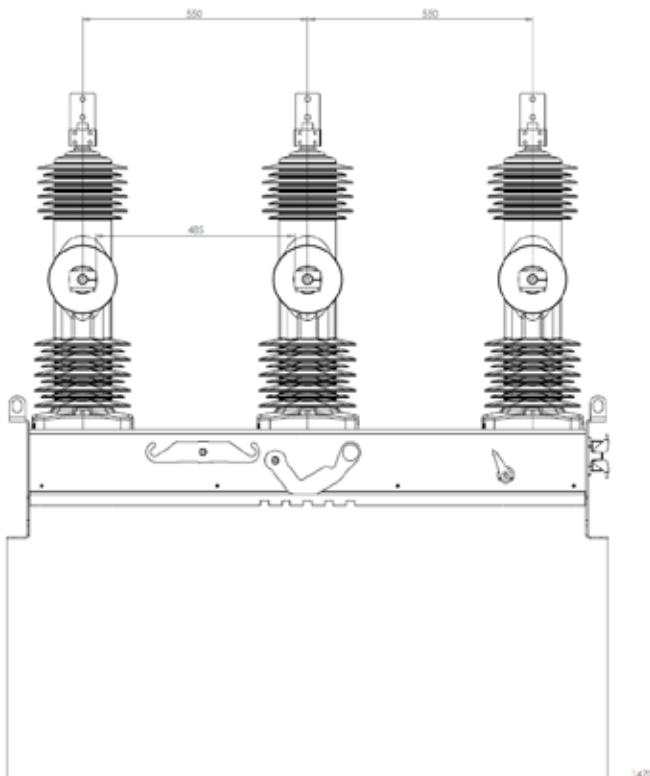

LBS LOAD BREAK SWITCHES

DRAWINGS

LBS120

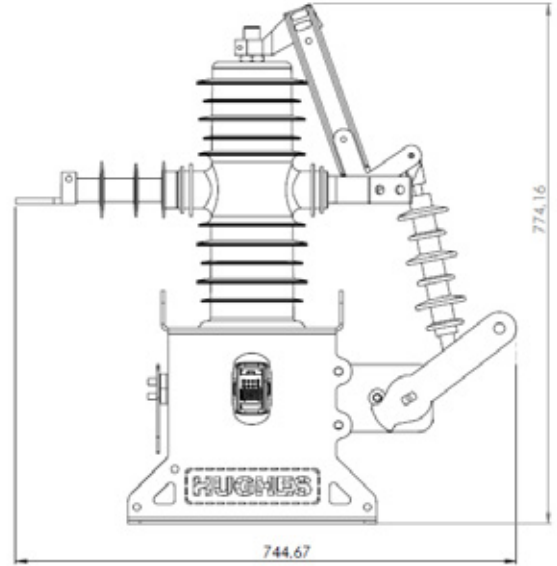
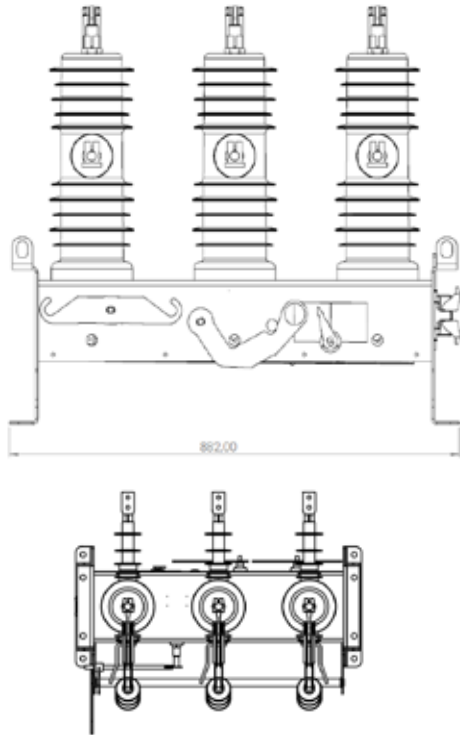

LBS121

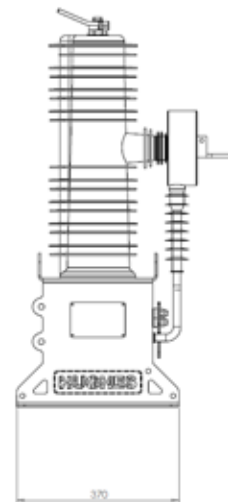
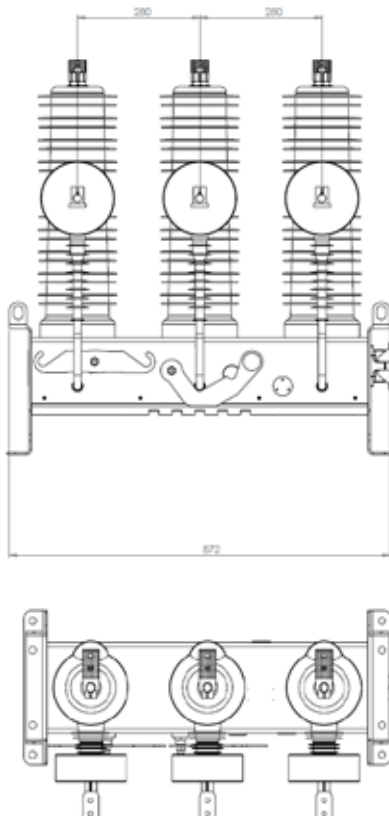

LBS240

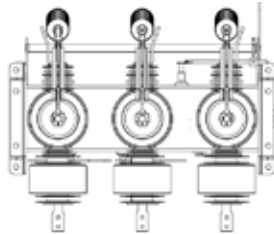
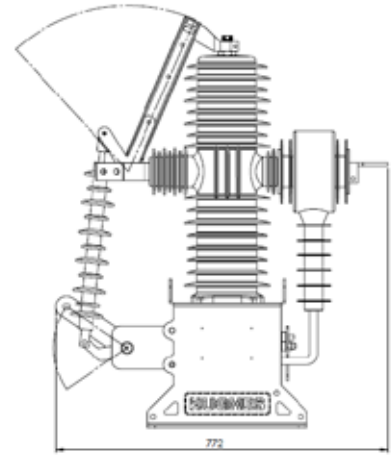
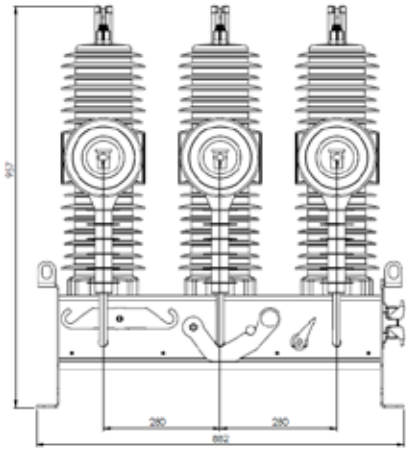

LBS241

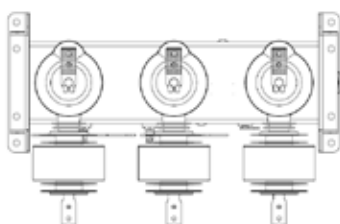
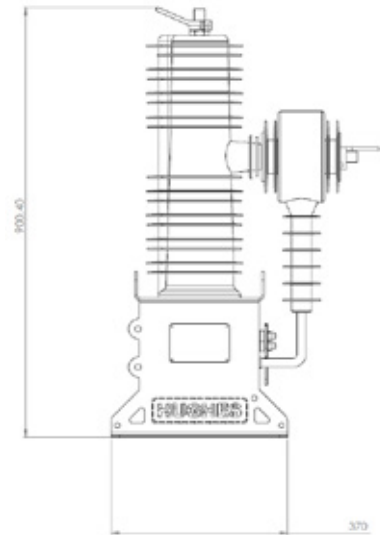
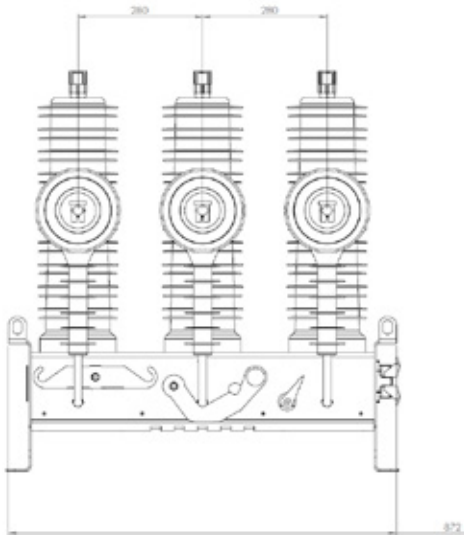

INSTALLATIONS

LBS120/121/240/241

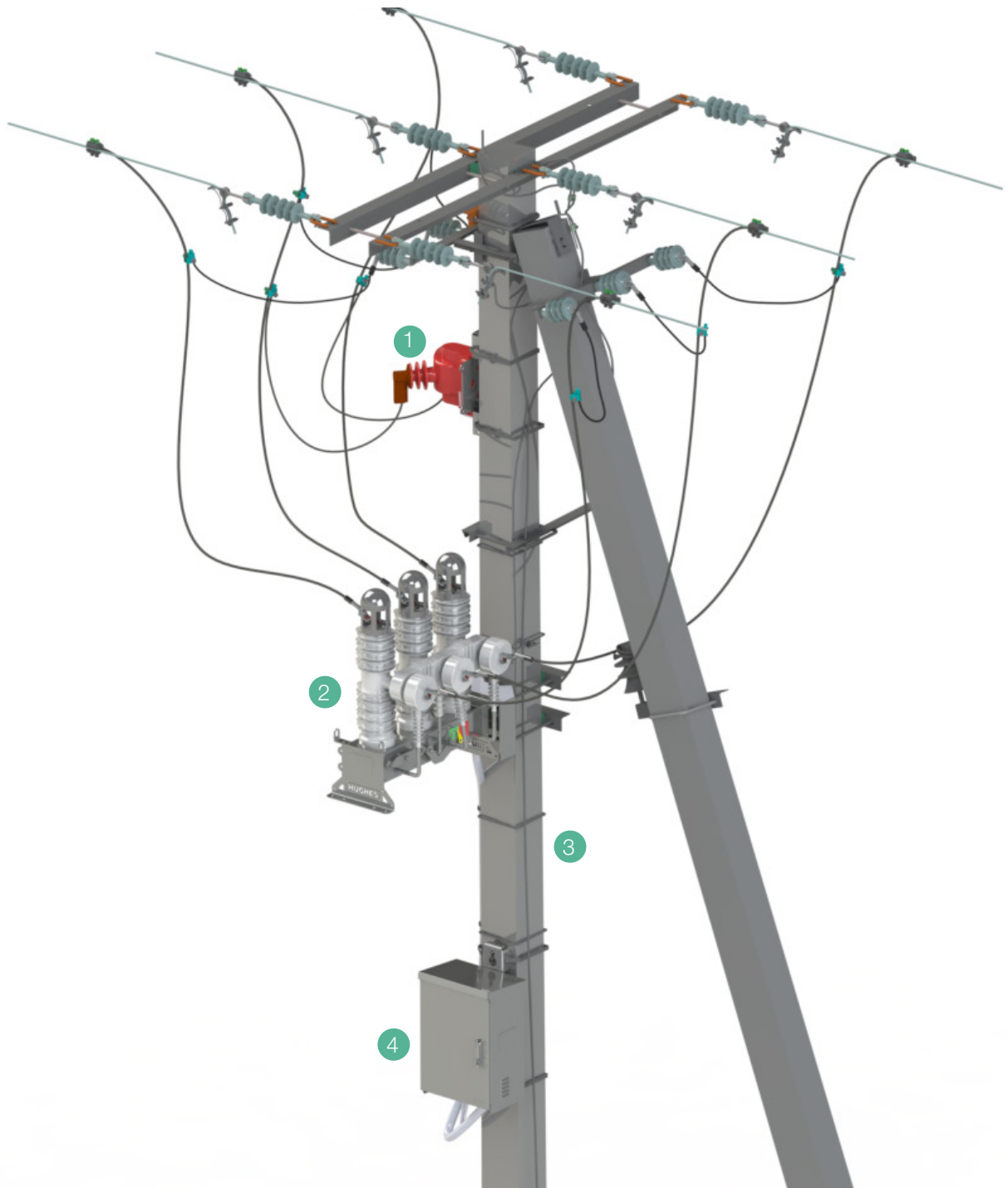

- Voltage transformer (1)
- Vacuum load break switch (2)
- Interconnecting cable (3)
- Control cabinet (4)

LBS405

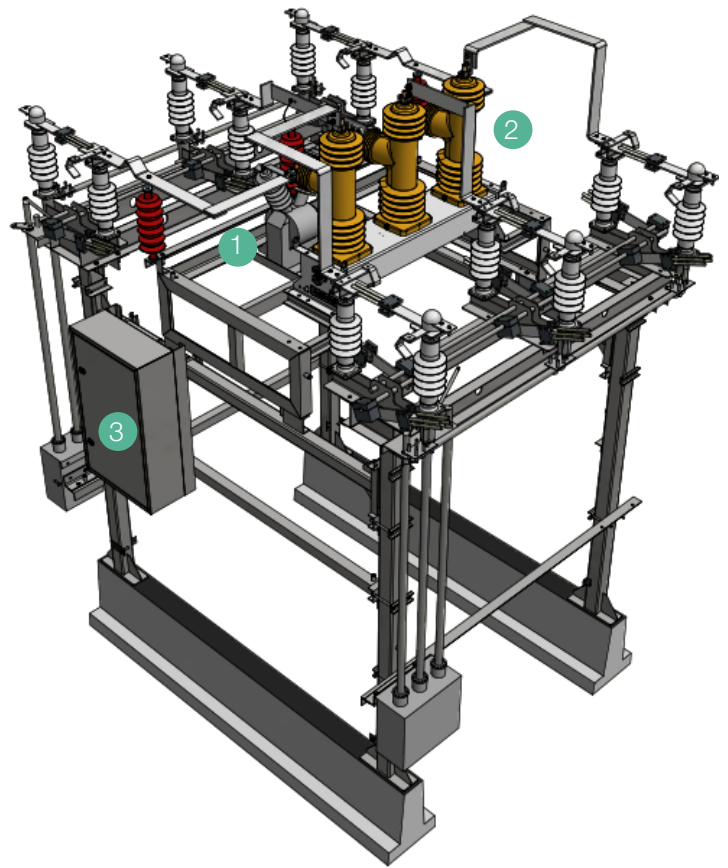
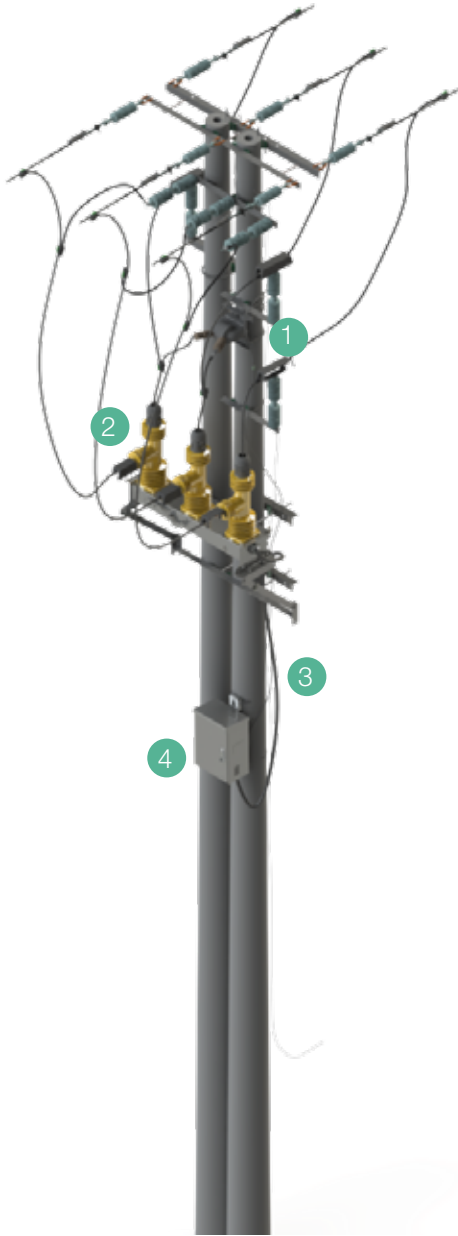

Installation of the LBS450 set inside of a sectionalizing scheme.

- Voltage transformer (1)
 - Vacuum load break switch (2)
 - Interconnecting cable (3)
 - Control cabinet (4)
- Voltage transformer (1)
 - Vacuum load break switch (2)
 - Control cabinet (3)

ADDITIONAL ACCESSORIES

NEW! FOR CXB-1 CONTROL CABINET GROUNDING SYSTEM CABLE THEFT ALARM

Grounding system cable theft alarm is an optional accessory that notifies SCADA system if the grounding system is missing or damaged.

It is installed inside a control cabinet and is suitable for all Hughes pole mounted products, such as:

- motor drives;
- overhead line and kiosk reclosers' protection relay cabinets;
- control cabinets for sectionalizers;
- control cabinets for vacuum circuit breakers or load break switches.



Installation in the motor drive cabinet

INDICATORS AND BUTTONS

When a ground wire of a control cabinet is cut, the red LED button is activated, and an immediate notification is sent to a SCADA system.

- The accessory has 3 indicators and one test button:
- POWER - on with a constant blue LED indicator;
- OK - with green LED displaying that ground system is normal;
- ALARM - with red LED displaying that the ground wire is cut;
- Test button - for testing the operation of the device;

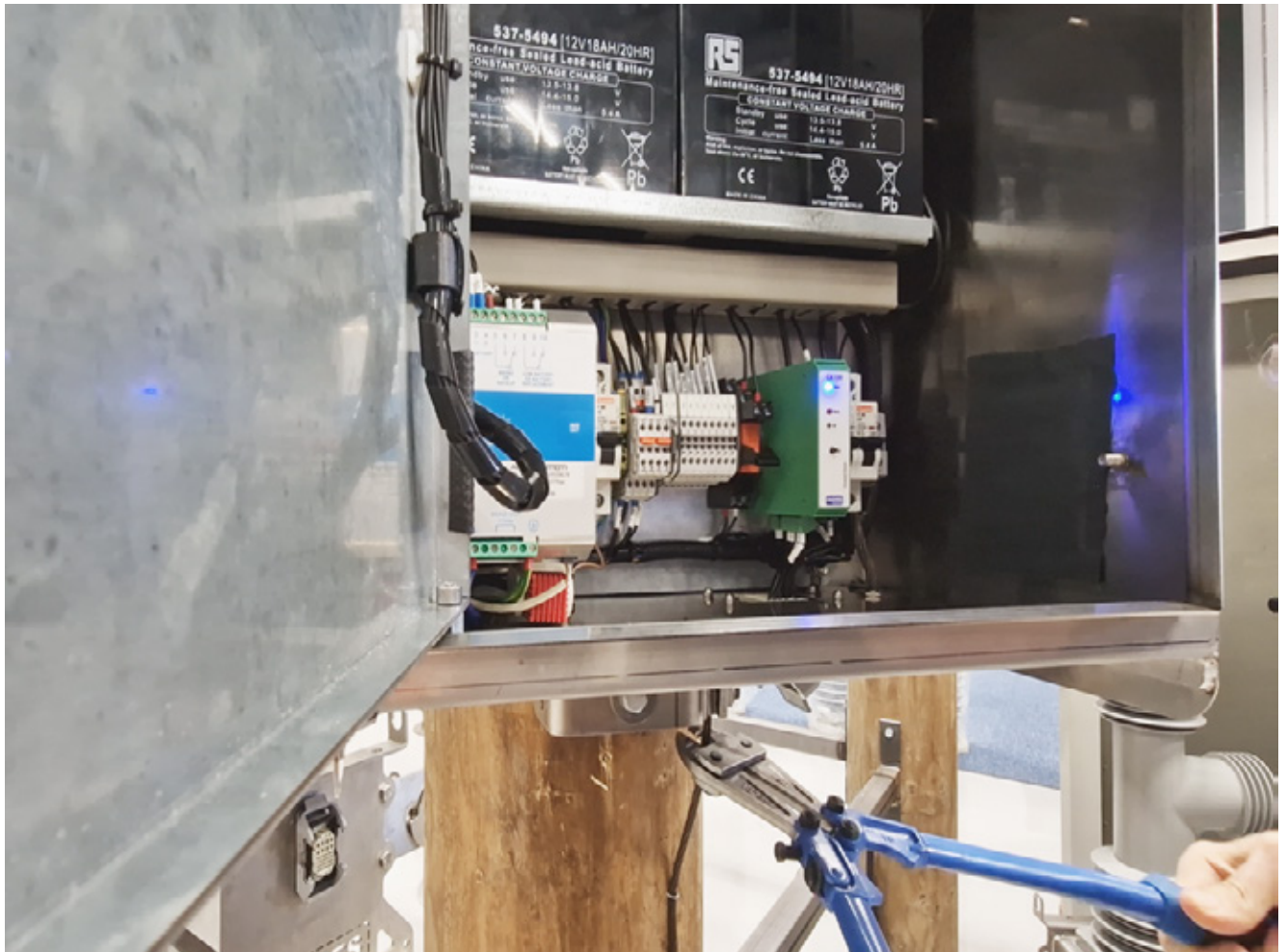

PURPOSES

The alarm is in high demand in regions with a big number of copper cable thefts.

The theft alarm purposes are:

- to receive immediate notification that the grounding system is missing;
- to help to prevent big electrical hazardous risks for the operator or public;
- to avoid receiving false measuring information from the remote device;
- to make it possible to repair the grounding system in the shortest time;

LBS LOAD BREAK SWITCHES

ADDITIONAL ACCESSORIES

FOR LBS AND CXB-1 CONTROL CABINET



CXB-1 mounting bracket



Phase to phase connected, epoxy insulated voltage transformer 11/0.11kV



Drop out fuses, silicone insulated, 15kV 3A



Phase to phase connected, epoxy insulated voltage transformer 24/0.11kV



Drop out fuses, silicone insulated, 38kV 3A



Multicore interconnection cable for OVX and FTU recloser control



Phase to phase connected, epoxy insulated voltage transformer 33/0.11kV



Surge arresters silicone insulated, 22kV



LBS mounting bracket



Phase to ground connected, epoxy insulated voltage transformer 19/0.11kV



Surge arresters silicone insulated, 33kV



Modem – Router G100



Modem – Router G200



Antenna for GSM/4G



Pole mounted bracket for antenna



Surge arresters for antenna
N-N connectors



Antenna cable (3) 8M RG-213 N-N
professional connectors;



Standard lead acid AGM type battery 12 V 20 AH;



Modem – Router G200 Li-Ion batteries for hot climate
with LiFePO₄ chemical system 12.8V 20 AH

LBS LOAD BREAK SWITCHES

TECHNICAL DATA

CHARACTERISTICS	CXB-1 control cabinet
Dimensions, mm	Wide body version 630 x 465 x 336 (HxWxD), multiple formats, custom fit
Weight, kg	46 (including batteries)
Operating temperature, °C	-50 ... +60 Optional -10...+80
Enclosure	IP55-65, non-magnetic stainless steel, optional painted in RAL or ANSI colour
Climate system	35 W PTC element
Thermostat, °C	on at 5°C off at 15°C
Operation voltage	90– 250VAC 240 W, temperature compensation;
Batteries	2 x 12 V 22 Ah AGM Lead cell
Battery optional	2 x 12.8 V, 22 AH Li-Ion
Control interface	Parallel
Tests	<ul style="list-style-type: none">• EN 60068-2-1• EN 60068-2-2• EN 60068-2-30• EN 60068-2-52• EN 60068-2-78• EN 62271-102 6.103• EN 62271-102 6.104• EN 62271-102 6.105• EN 60265

CHARACTERISTICS	LBS120 / 121 for 6/15kV	LBS240 / 241 for 22/27kV	LBS405 for 33/40kV
Dimensions LxWxH, mm	882x745x775 / 872x370x902	882x772x957 / 872x370x900	1470x621x1070
Mass (weight) without air break switch, kg (lbs)	75 (165) / 75 (165)	101 (222) / 101 (222)	155 (342)
Mass (weight) with disconnecter, kg (lbs)	98 (216) / NA	125 (275) / NA	NA
Operating temperature, °C	-45 - +70 / -45 - +70	-45 - +70 / -45 - +70	-45 - +70
Humidity	100% at 25C / 100% at 25C	100% at 25C / 100% at 25C	100% at 25C / 100% at 25C
Enclosure	IP55-65, non-magnetic stainless steel, optional painted in RAL or ANSI colour	IP55-65, non-magnetic stainless steel, optional painted in RAL or ANSI colour	IP55-65, non-magnetic stainless steel, optional painted in RAL or ANSI colour
Bushing type	Epoxy core with silicone surface	Epoxy core with silicone surface	Hydrophobic Cycloaliphatic Epoxy (HCEP)
Phase to phase distance, mm	280 /280	280 / 280	550
Creep distance to ground (airbreak switch isolator), mm	400	725	
Creep distance to ground (interruptor isolator), mm	460 / 1090	960 / 1090	1310 (opt. 1610)
Max installation altitude at rated BIL, m	3000 / 3000	3000 / 3000	3000
Rated operation voltage, VDC	24-48-110	24-48-110	24-48-110
Rated maximum voltage, kV	12 / 15	24 / 27	38 / 40
Rated basic impulse level, P>P, kV	85 / 85	145 / 145	185
Rated basic impulse level, P>E, kV	75 / 75	125 /125	170
Power frequency withstand, Dry, kV	60 / 60	60 / 60	70
Power frequency withstand, Wet, kV	45 / 45	50 / 50	60
Rated continuous current, A	630 / 1250	630 / 1250	1200
Rated fault peak current, kA	50 / 50	50 / 50	42
Rated fault breaking current, kA	20 / 20	20 / 20	16
Cable charging current, A	20 / 40	20 / 40	40
Line charging current, A	5 / 10	5 / 10	5
Rated fault duration time, s	3 / 3	3 / 3	3
Contact resistance, VCB, $\mu\Omega$	< 35 / <35	< 35 / <35	< 40
Contact resistance, ABI, $\mu\Omega$	< 60	< 60	
Network frequency, Hz	50/60 / 50/60	50/60 / 50/60	50/60
Design min mechanical/electrical	20.000 / 20.000	20.000 / 20.000	20.000 / 20.000
Rated power, W	40 / 40	40 / 40	40
Design specification	IEC 62271-100	IEC 62271-100	IEC 62271-100
Marking specification	IEEE std C37.60	IEEE std C37.60	IEEE std C37.60
Operation sequence, no charge	25ms trip - 50ms close - 25ms trip	25ms trip - 50ms close - 25ms trip	25ms trip - 50ms close - 25ms trip



Hughes Power System is a Swedish manufacturer of environmentally friendly equipment for electrification and automation of mass transport and electrical distribution systems. Very high quality standards together with innovative approach result in an advanced range of products, aiming to improve network quality by minimizing the number and duration of faults.

The majority of Hughes Power System's products are designed and built in Sweden.

www.hughespowersystem.com

